

LIFT KING 12/2-Post Floor-plate Service Hoist

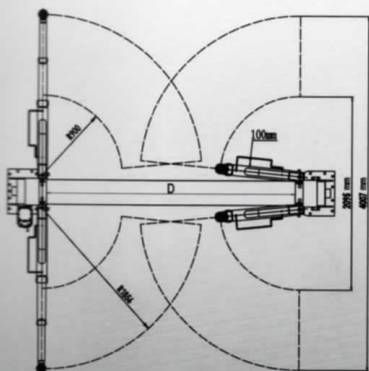

FEATURES

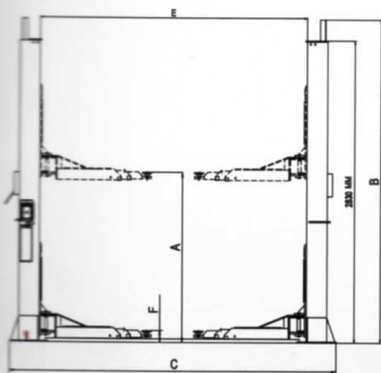

- 12,000 Lb. Capacity
- Dual hydraulic cylinders, designed and made on ANSI standards, high quality NOK seals
- 3/8" aircraft quality cable is used for synchronization
- Self-lubricating UHMW Polyethylene sliders and bronze bushings
- Single-point safety release
- Automatic arm restraints
- Width adjustment: Distance between columns 3137mm(123 1/2") and 3000mm(118 1/8")
- Stackable rubber pads with 1.5", 3" and 6" adaptor for truck
- Heavy duty design

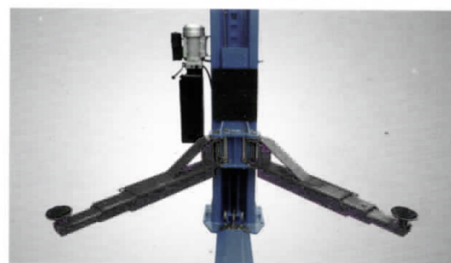

Our Heavy-Duty Base-plate lifts use 3-Stage Arms - to more easily allow for short or long axle vehicle lifts...

We Sell Peace Of Mind...
1300 79 5438 • 0413 29 3318
www.herohoists.com.au

SPECIFICATIONS

Model	Style	Lifting Capacity	Lifting Time	A	B	C	D	E	F	Gross Weight	Motor
				Lifting Height	Overall Height	Overall Width	Drive-Thru Clearance	Width Between Columns	Minimum Pad Height		
12/2-Post BP	Floorplate Chain-drive	5.5 T (12,000 lbs.)	55 Seconds	1825-2095mm (72"-82 1/2")	3065mm (120 5/8")	3692/3829mm (145 3/8"-150 3/4")	2790/2927mm (109 7/8"-115 1/4")	3000/3137 mm (118 1/8"-123 1/2")	105 mm (4 1/8")	980kg (2,156 lbs)	4.0HP